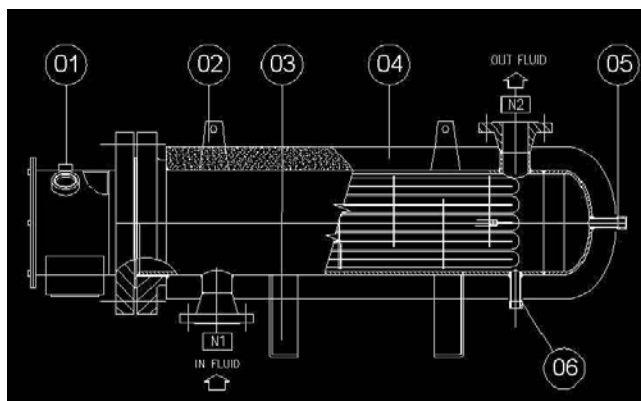

Figure 1: Typical Sketch of an electrical heat exchanger



GENERAL CHARACTERISTICS

Heat Exchangers are the best solution to heat fluids flowing in forced convection.

Electrical Heat Exchangers operate in the same way as fluid/fluid heat exchanger but the hot side consists of armoured electrical heaters in direct contact with the fluid to be heated. An optimum heat exchange is obtained employing appropriate baffles whose design is tailored to exploit at best the heat released by the electrical resistances.

Thanks to the specific characteristics of the heaters, the Electrical Heat Exchangers are very compact in size and support a very precise control of the fluid outlet temperature. These systems, in fact, are characterised by a minimum thermal inertia of the hot side of the exchanger, thus providing a very fast response to the process needs and a finely controlled outlet temperature. This is especially true if SCR's (Solid Control Relais) are employed in the control system.

These products are designed by our technical department on the basis of customer provided functional requirements. Design is supported by purpose-developed software that allow both the definition of the design parameters and the verification of the corresponding thermodynamic performances. The analysis yields a precise picture of the heat exchanger operating conditions. The iteration between design and analysis leads to define:

1. the specific power
2. the requested number and type of baffles as well as the resulting **pressure drops**
3. the **maximum sheath temperature** and, consequently, the safety devices to be used
4. the materials to be used in the construction
5. The heat exchanger main dimensions
6. the thermodynamic behaviour of the heat exchanger in the different operational conditions that are foreseen

TECHNICAL DATA

(see also Figure 1)

Heat Exchanger can be manufactured with carbon steel or stainless steel shell:

- 1 Power supply cable inlet
- 2 Eyelets for heat exchanger hoisting or moving
- 3 Supporting frames for mechanical fixation
- 4 Thermal insulation (if requested)
- 5-6 Drain connections



The manufacturing experience built up in several years of operation in the market, coping with the most different applications, enables us to suggest to our customers materials and technical solutions which are best suited to the application of interest.

The results of the thermodynamic calculations, performed to prove the capability of the heat exchanger to operate as requested, are provided already as part of the offer.

If requested by customer specifications, mechanical verification calculations, for the structurally significant parts (coupling flanges and shell), are provided in the frame of the order. They fulfil the requirements of European (PED 97/23/EC), American (ASME VIII div.1) and are executed following national (VSR, AD2000, etc.) standards.

APPLICATIONS

- ↪ Heating of moulds or blocks containing fluid-circulating loops
- ↪ Oil separation and filtration
- ↪ Combustible oils pre-heating
- ↪ hot transfer of heavy oils
- ↪ Hot water supply to cleaning and rinsing tanks
- ↪ Anti-frost protection
- ↪ Technical and process gases heating
- ↪ Additional heating unit (back-up of the primary one)

DEFINITION OF THE TYPE OF HEATING

The sizing of a heat exchanger changes significantly if the requested heating shall be obtained in a single passage of the fluid ("single passage" heating) or if, on the contrary, it can be the result of several passages through the heat exchanger ("re-circulating" heating).

The two sketches presented hereunder show synthetically the typical features of each of these two heating concepts.

Functional Scheme for a SINGLE PASSAGE electrical heat exchanger

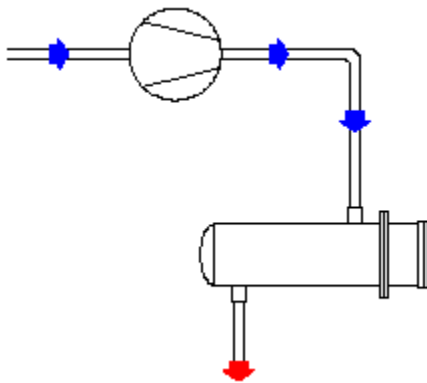

The fluid is heated **in a single passage**, to be directly injected into the production process.

The plant consists typically of:

1. Fluid arriving from the users
2. A pump
3. A heat exchanger

These systems are best suited to heat in a very short time liquids, gases or mixture fluids flowing from networks, tanks and production processes.

This system is to be used in the processes which absorb totally the outlet fluid enthalpy. In these processes the fluid returns cold to the heat exchanger inlet.

Functional Scheme for a RE-CIRCULATING electrical heat exchanger

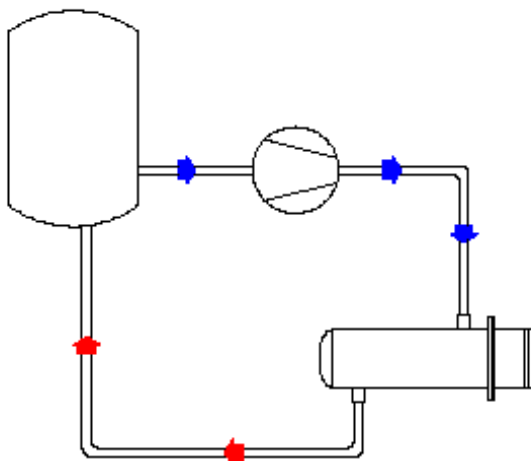

The fluid is heated in **more than one passage** and, once reached the desired temperature, is injected into the production process.

This solution, if compared to the former one, allows to optimise the energy consumption and to reduce the heat exchanger size and installed power. This result is obtained at the price of a longer fluid heating time. In addition, a storage tank or basin is also required to support adequately the production process.

The plant consists typically of:

1. A tank (or a storage basin)
2. A pump
3. A heat exchanger

DATA REQUIRED FOR A CORRECT DEFINITION OF A HEAT EXCHANGER

To design the heat exchanger a set of data is required. The availability of all the data is a pre-requisite for an optimum sizing and for a precise definition of the heating power. The Table 1 presented hereunder summarises the required data.

Table 1: data required to design an electrical heat exchanger

Design Data	Notes																										
Thermodynamic Data																											
Fluid	⇒ For non common fluids please specify the thermodynamic characteristics at, at least, three different temperatures <table border="1" style="width: 100%; border-collapse: collapse;"> <thead> <tr> <th style="background-color: #003366; color: white;">thermodynamic properties</th> <th style="background-color: #003366; color: white;">M.U.</th> <th style="background-color: #003366; color: white;">Temp °C</th> <th style="background-color: #003366; color: white;">Temp. °C</th> <th style="background-color: #003366; color: white;">Temp. °C</th> </tr> </thead> <tbody> <tr> <td style="background-color: #003366; color: white;">Density</td> <td style="background-color: #003366; color: white;">Kg/m³</td> <td></td> <td></td> <td></td> </tr> <tr> <td style="background-color: #003366; color: white;">Thermal conductivity</td> <td style="background-color: #003366; color: white;">W/(m°K)</td> <td></td> <td></td> <td></td> </tr> <tr> <td style="background-color: #003366; color: white;">Viscosity</td> <td style="background-color: #003366; color: white;">cP</td> <td></td> <td></td> <td></td> </tr> <tr> <td style="background-color: #003366; color: white;">Specific Heat</td> <td style="background-color: #003366; color: white;">J/(kg°K)</td> <td></td> <td></td> <td></td> </tr> </tbody> </table> More information on fluids characteristics are contained in the “Useful Technical Information” Volume	thermodynamic properties	M.U.	Temp °C	Temp. °C	Temp. °C	Density	Kg/m ³				Thermal conductivity	W/(m°K)				Viscosity	cP				Specific Heat	J/(kg°K)				
thermodynamic properties	M.U.	Temp °C	Temp. °C	Temp. °C																							
Density	Kg/m ³																										
Thermal conductivity	W/(m°K)																										
Viscosity	cP																										
Specific Heat	J/(kg°K)																										
Fluid flow rate	⇒ If variable please specify min. and max value in kg/h																										
Design pressure	⇒ in bar absolute																										
Maximum operating pressure	⇒ in bar absolute																										
Maximum allowable pressure drop	⇒ in mm H ₂ O																										
Design Temperature	⇒ in degrees centigrade																										
Inlet Temperature	⇒ in degrees centigrade																										
Outlet Temperature	⇒ in degrees centigrade																										
Type of heating (see explanation in previous page)	⇒ Re-circulating ⇒ Single passage																										
Installation	⇒ Vertical / Horizontal ⇒ Outdoor / Indoor																										
Type of connection to the fluid loop	⇒ Flange connection / Screwed connection																										
Envelope	⇒ Please specify max. envelope, all included																										
Masses to be heated	⇒ Please specify the most significant plant masses (weight and materials) that are heated by the flowing fluid																										
Electrical Data																											
Installed Power	⇒ in kW																										
Power Supply Voltage	⇒ in Volt																										
Type of Electrical connection	⇒ Star / Delta / Monophase																										
Number of stages	⇒																										
Contact Head Protection	⇒ IP 55/65																										
Control																											
Power	⇒ On/Off ⇒ SCR (Solid Control Relais) ⇒ On/Off + SCR																										
Fluid thermal sensor	⇒ please specify number and type																										
Sheath thermal sensor	⇒ please specify number and type																										

NOTE: Data in bold character must be provided to insure a correct sizing of the heater. For the remaining data, missing specific customer information, Masterwatt standards will be applied

Additional information are required if optional components (thermal insulation or cable glands) are to be supplied with the heat exchanger or if the heat exchanger design shall comply with the requirements of specific standards. The data in Table 1, in this case, must be completed with those listed in Table 2.

Table 2: design data to be provided in case optional components or specific certifications are required

Accessories	Notes	
Thermal Insulation	Masterwatt Standard as a function of the operating temperature	
Cable glands	Please specify: material and Φ external of the power supply cable	
Certifications and calculations		
Pressure Equipment	⇒ 97/23/CE (PED); ASME	
Pressure Equipment calculation codes	⇒ VSR; AD2000; ASME VIII Div. 1°	
Equipment installed in potentially explosive areas	⇒ ATEX	
	Dangerous area classification	
	Zone	
	Maximum allowable temperature class (e.g. T3)	
	Ambient Temperature (e.g. -10°C + 40 °C)	
More information inside the Explosion Proof Heater catalogue.		

Two examples of heat exchanger and of their related design data are shown in Figure 2 and 3:

Sea Water Heat Exchanger



Figure 2

Design Data

Fluid	Sea water
Design pressure	9 bar
Dimensions	Φ 20"x2600
Power	600 kW
Power supply voltage	380 V/3ph
Operating temperature	90 °C
<u>Materials:</u>	
Shell	Inox AISI 316
Heating elements	Titanium
Flange	Titanium
Baffles	Titanium

Heavy Naphtha Heat Exchanger

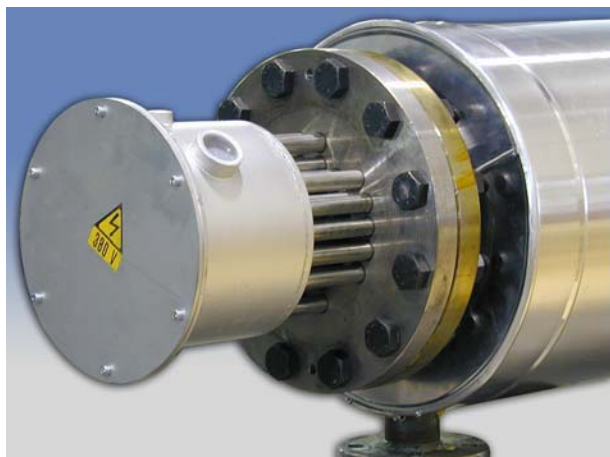

Figure 3

Design Data

Calculation Code	ASME
Fluid	Heavy Naphtha
Design pressure	15 bar
Dimensions	Φ 8"x2400
Power	52 kW
Power supply voltage	400 V/3ph
Operating temperature	150 °C
<u>Materials:</u>	
Shell	ASTM A 106
Heating elements	Inox AISI 316
Flange	ASTM A 105
Thermal Insulation	Glass wool and aluminium cover