

PIROSLIM - Thin Nozzle Heaters -

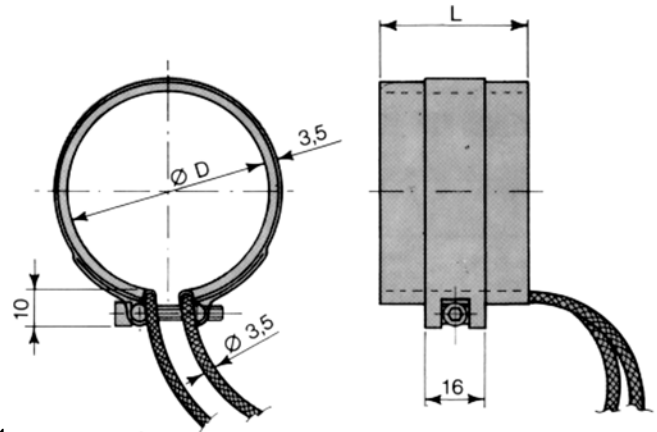

Figure 1

GENERAL CHARACTERISTICS

In many cases only a limited clearance is available between nozzle and mould (e.g. in hot-chamber moulds). In these cases, UGL heaters cannot be used due to their thickness and PIROSLIM heaters represent the ideal solution. They are characterised by a high specific power (5 W/cm^2) and, consequently, are best suited whenever the heat demand in the injection area needs to be increased. Finally, thanks to the employ of stainless steel in the external sheath, these heaters are recommended whenever the melted plastic materials is corrosive (PVC and others).

APPLICATIONS

These heaters are employed in all the plastic moulding machines where the operational temperature does not exceed $350 \text{ }^\circ\text{C}$.

TECHNICAL DATA (see Figure 1)

1. **RESISTIVE WINDING** made of Nickel/Chrome 80/20
2. **ELECTRICAL INSULATION** made of high purity continuous mica with a very low presence of binder
3. **SHEATH** made of high-conductivity treated steel, closed to prevent plastic material penetration and presenting a high resistance to corrosion
4. **POWER SUPPLY** via cables suitable for high temperatures. The cables internal conductors are in pure nickel, the internal insulation is in fibreglass-Teflon and the external protection is a high mechanical resistance stainless steel sheath. The cable standard length is 1000 mm. Thanks to a special construction, the heater package includes at one end, well protected beneath the insulation layers, the junction between the power supply cables and the heating circuit. This solution guarantees a solid blockage of the cables.
5. **SPECIFIC POWER** 5 W/cm^2 .
6. **OPERATING TEMPERATURE** $350 \text{ }^\circ\text{C}$
7. **CLAMPING** onto nozzle by tying-bands provided with internal hex-head screws (1 band up to 35 mm width, 2 bands from 36 to 60 mm and 3 bends behind 60 mm)

INSTALLATION

When installing, please make sure that the heater internal surface perfectly adheres to the nozzle. Then tighten adequately the hexagonal-head screws provided with the heater. After initial operation (30 minutes) tighten again the screws in order to compensate the thermal expansion.

STANDARD DIMENSIONS

PIROSLIM heaters are manufactured in standard dimensions as detailed in Table 1. They are available on stock: to order them simply specify the code.

SPECIAL CONSTRUCTIONS

When required, non-standard PIROSLIM heaters can be manufactured. In particular it is possible to:

- Provide heaters with special dimensions provided that the diameter does not exceed 100 mm and the width 100 mm
- Provide heaters with embedded "J"-Type thermocouple
- Provide power supply cables with a length that is different from the standard (1000 m)
- Provide heaters with heating power or power supply voltage that are different from those specified in Table 1 as long as the specific power does not exceed 5 W/cm^2 .
- Provide heaters with a hole to allow the introduction of a thermal sensor

If non standard power supply and/or voltage constructions are requested, our technical department shall check the feasibility.

If a hole to allow the introduction of a thermal sensor is required, a drawing shall be supplied which clearly shows the hole dimension and the desired position.

Table 1: PIROSLIM heaters available on stock

SPECIFIC POWER 5 W/cm ² - 230 V							
ΦD (mm)	L (mm)	Power (Watt)	Code	ΦD (mm)	L (mm)	Power (Watt)	Code
25	30	120	14025030	70	20	220	14070020
30	25	120	14030025	70	25	270	14070025
30	30	140	14030030	70	30	330	14070030
30	35	165	14030035	70	35	385	14070035
30	40	185	14030040	70	40	440	14070040
35	25	135	14035025	70	50	550	14070050
35	30	165	14035030	70	60	660	14070060
35	35	190	14035035	75	20	235	14075020
35	40	220	14035040	75	25	295	14075025
35	45	235	14035045	75	30	355	14075030
40	25	155	14040025	75	35	410	14075035
40	30	190	14040030	75	40	470	14075040
40	35	220	14040035	75	50	590	14075050
40	40	250	14040040	75	60	705	14075060
40	45	280	14040045	80	20	250	14080020
42	25	165	14042025	80	25	310	14080025
42	30	200	14042030	80	30	375	14080030
42	35	230	14042035	80	35	440	14080035
42	40	265	14042040	80	40	500	14080040
45	25	175	14045025	80	50	630	14080050
45	30	210	14045030	80	60	750	14080060
45	35	250	14045035	85	20	265	14085020
45	40	280	14045040	85	25	330	14085025
45	45	320	14045045	85	30	400	14085030
45	50	350	14045050	85	35	465	14085035
50	20	155	14050020	85	40	530	14085040
50	25	195	14050025	85	50	665	14085050
50	30	235	14050030	85	60	800	14085060
50	35	275	14050035	90	20	280	14090020
50	40	315	14050040	90	25	350	14090025
50	50	390	14050050	90	30	420	14090030
55	20	170	14055020	90	35	490	14090035
55	25	215	14055025	90	40	565	14090040
55	30	260	14055030	90	50	705	14090050
55	35	300	14055035	90	60	845	14090060
55	40	345	14055040	95	20	300	14095020
55	50	430	14055050	95	25	370	14095025
60	20	190	14060020	95	30	445	14095030
60	25	235	14060025	95	35	520	14095035
60	30	280	14060030	95	40	595	14095040
60	35	330	14060035	95	50	745	14095050
60	40	375	14060040	95	60	895	14095060
60	50	470	14060050	100	20	315	14100020
60	60	565	14060060	100	25	390	14100025
65	20	200	14065020	100	30	470	14100030
65	25	255	14065025	100	35	550	14100035
65	30	305	14065030	100	40	630	14100040
65	35	355	14065035	100	50	785	14100050
65	40	405	14065040	100	60	940	14100060
65	50	510	14065050				
65	60	610	14065060				