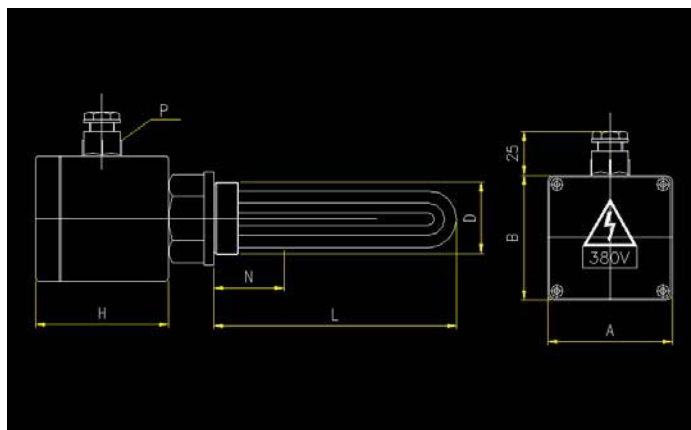

Figure 1: Typical sketch of an electric heater mounted on a threaded plug



GENERAL CHARACTERISTICS

The electric heaters mounted on a threaded plug have been conceived to satisfy the most different needs in the heating of liquid substances, both in the industrial and in the civil applications.

They are designed to be inserted into tubes, basins or pressurised tanks and they are sunk in direct contact with the fluid. Thanks to the presence of armoured electrical heaters, the heat exchange is very effective and it is possible to design very compact heaters.

These heaters are quite different from the flange-mounted heater: they are normally smaller and their heating power is lower.

These products are designed by our technical department on the basis of customer provided functional requirements. The design takes into account the physical, chemical and thermodynamic characteristics of the fluid to be heated, as well as the operating temperature, the features of the site and the allowable clearance in the area where the heater will be installed. The iteration between design and analysis leads to define:

1. the specific power and the required number of heating elements (1 or 3)
2. the threaded-plug dimensions
3. the maximum sheath temperature and, consequently, the safety devices to be used
4. the materials to be used in the construction
5. the dimensional characteristics of the heater

Thanks to the accumulated experience, to the data collected during in-house testing and to the return information provided by our customers, we can today propose the most appropriate materials and solutions to the customer.

The main characteristics of the heaters are defined in a technical data sheet, provided with the offer, which allows the customer verify the main electrical data and the mechanical interfaces to the plant.

TECHNICAL DATA

(see also Figure 1)

D	Threaded Plug Diameter
L	Maximum Length Below Ledge
N	Neutral (non heating) section
H	Electrical contact box height
A/B	Electrical contact box side envelope
P	cable gland



TYPICAL INDUSTRIAL APPLICATIONS

- ↗ Oil pre-heating in lubrication gear cases
- ↗ Pre-heating of combustible oils in tanks
- ↗ anti-frost protection in storage tanks
- ↗ Hot/Warm water supply
- ↗ Food industry machinery
- ↗ Back-up heating unit

STANDARD HEATERS

Many application require heaters mounted on threaded plugs to **heat water or oil**. In these common situations, the possibility to select easily the required heater and trust on a **fast delivery** turns out to be very useful.

To cope with this need, a catalogue of heaters mounted on a threaded plug (**PLUG & PLAY heaters**) has been set-up. For these heaters the heating elements are ready on stock and, consequently, the **delivery** is normally feasible after **few days from the order**.

The main features of these heaters are:

1. Threaded **plug made of brass** and provided with a hexagonal wrench interface for heater installation
2. **Heating elements** fixed onto the plug by means of **braze welding**. The soldering alloy allows operating pressure up to 12 bar (provided that a proper seal is used).
3. Neutral (i.e. non heating) section length equal to 40 mm
4. Two alternative possible for contact head:
 - a. **IP40 degree of protection** made of **Aluminium** (2 mm thick, maximum operating temperature 200 °C) provided with a rubber pass-through for power supply cable inlet (hole diameter = 12 mm for 1" ¼ and 1" ½ plugs, = 17 mm for 2" plugs and = 18 mm for 2" ½ plug)
 - b. **IP65 degree of protection** made of **polycarbonate** (operating temperature range -60 ÷ 125 °C), provided with a ½" Gas cable gland.
5. Possibility (only for IP65 contact box and not on all models) to provide the heater with embedded safety or regulation thermostat (measurement range: 30 ÷ 90 °C for 7 W/cm² heaters and 40 ÷ 220 °C for 2 W/cm²)

The typical **envelope** of these heaters are shown in **Figure 2** (heater with **IP40** contact box) and **Figure 3** (heater with **IP65** contact box). Table 1 summarises the main features of the threaded plugs.

Table 1: dimensional characteristics of threaded plugs

Nominal diameter	Thread external diameter (mm)	Thread Height (mm)	Wrench diameter (mm)	Material
1" ¼ Gas	41,9	15	43	Brass
1" ½ Gas	47,8	15	43	Brass
2" Gas	59,6	15	57	Brass
2" ½ Gas	75,1	20	86	Brass

Figure 2: typical envelope of a heater provided with an **IP40 contact box**

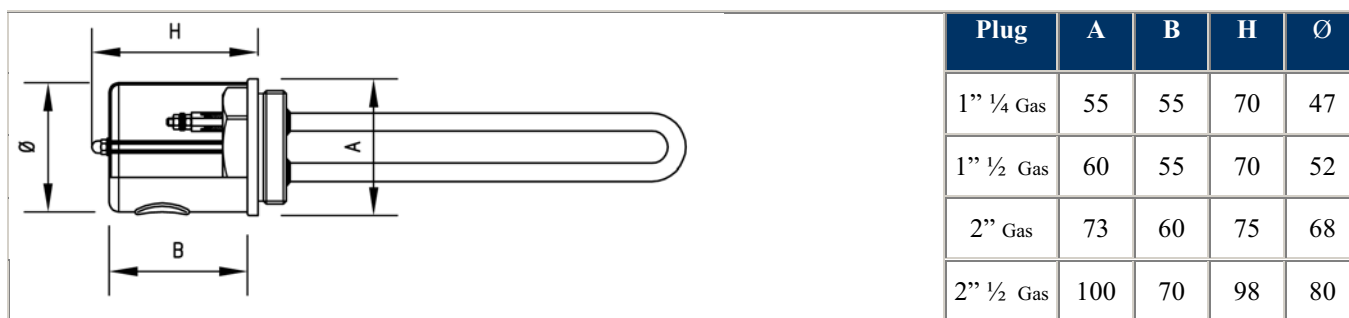
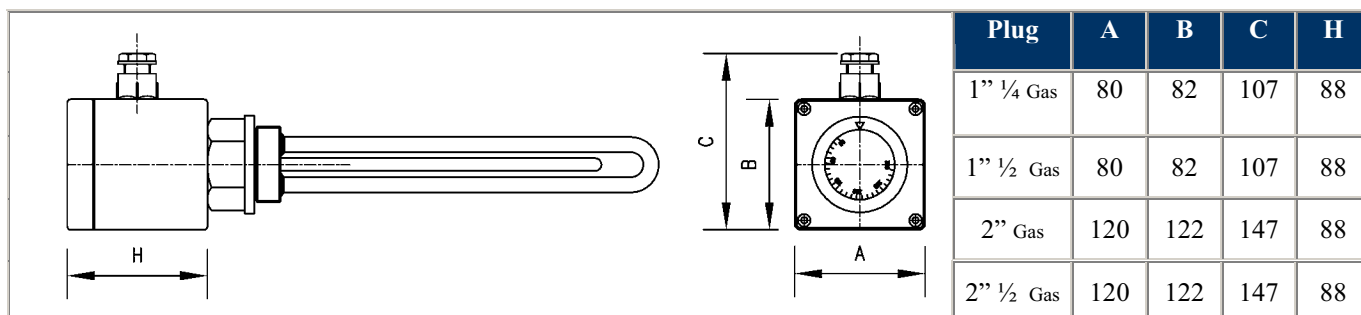

Figure 3: typical envelope of a heater provided with an **IP65 contact box**



These heaters can be provided in the following versions:

- Power supply at 230 V (monophase - 1 heating element) or at 400 V (tri-phase - 3 heating elements – star connection). 230V power supply (3 elements - delta connection) is also possible
- Specific power equal to 7 W/cm² or 2 W/cm²
- Available plugs: 1" ¼ Gas, 1" ½ Gas, 2" o 2" ½ Gas (the possibility to supply all the different heater typologies with all these threaded plugs changes from model to model)
- IP40 (aluminium) or IP65 (polycarbonate) contact box
- With or without thermostat (the version with thermostat is available only with IP65 contact box and is not present in all models)

In all cases the heating elements area made using an AISI 316Ti sheath. Their diameter can be 10 mm or 16 mm.

To choose one of our standard heaters, the following, first of all, shall be taken into account::

- To heat water the recommended heaters are those having a specific power of **7 w/cm²**, while for oil heating only **2 W/cm²** specific power heaters can be employed
- Standard heaters, due to their inherent manufacturing characteristics, **are not suitable** to heat: **demineralised or deionised water as well as hydraulic oils**. In these cases our Technical Department shall be contacted: a dedicated technical and cost proposal, tailored to the application needs, will be prepared. To prepare this type of offer, the data listed in Table 1 (see last page of this catalogue) shall be provided to our Technical Department.

PLUG & PLAY HEATER SELECTION

To select the heater suitable to your needs, the following steps shall be undertaken:

1. select the most appropriate specific power value depending on the application of interest
2. select, amongst the tables listed in next pages, those compatible with the desired power supply conditions
3. choose, within the tables that fulfil the first two selection criteria (specific power and voltage coherent with the application) that product whose dimensions (length below ledge), heating power, characteristics of the contact head (IP40 or IP65) and possibility to incorporate the thermostat, complies with the requirements of the application

4. mention the selected product code in the request for quotation or in the order that it is planned to issue. In defining the product code, the information in the tables below shall be taken into account:

Contact Head Type	CC Code
IP40	23
IP65 without thermostat	71
IP65 with thermostat	72

Plug Thread	F Code
1" ¼	T
1" ½	U
2"	V
2" ½	Z

HEATER WITH IP40 CONTACT HEAD



HEATER WITH IP65 CONTACT HEAD

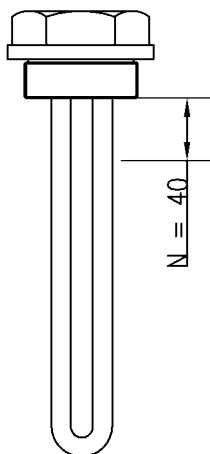
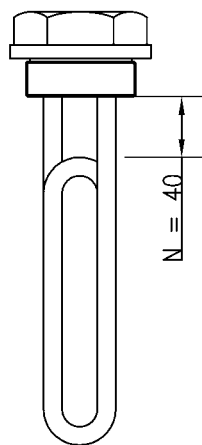
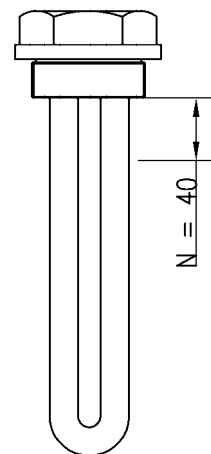

“PLUG & PLAY” HEATERS WITH HEATING ELEMENTS READY ON STOCK

N° 1 element Ø 10

N° 1 element Ø 10, 3-bents

**N° 1 element Ø 16
Mounted on a 2" ½ plug**

2 W/cm ² - 230 V monophasé		
CODE	L mm	Watt
CCF101033500300	335	300
CCF101040500400	405	400
CCF101046500500	465	500
CCF101059500650	595	650
CCF101072500850	725	850
CCF101086501000	865	1000
CCF101099501200	995	1200
CCF101140001650	1400	1650

2 W/cm ² - 230 V monophasé		
CODE	L mm	Watt
CCF101019000300	190	300
CCF101021500400	215	400
CCF101026000500	260	500
CCF101032000650	320	650
CCF101039000850	390	850
CCF101045001000	450	1000
CCF101052001200	520	1200
CCF101072001650	720	1650

2 W/cm ² - 230 V monophasé		
CODE	L mm	Watt
CCZ161031000500	310	500
CCZ161038000650	380	650
CCZ161046000800	460	800
CCZ161056001000	560	1000
CCZ161068001250	680	1250
CCZ161081001500	810	1500
CCZ161093001750	930	1750
CCZ161106002000	1060	2000

7 W/cm ² - 230 V monophasé		
CODE	L mm	Watt
CCF101021500650	215	650
CCF101025500850	255	850
CCF101029501000	295	1000
CCF101033501200	335	1200
CCF101036501350	365	1350
CCF101045001650	450	1650
CCF101051502000	515	2000
CCF101067502600	675	2600
CCF101082503300	825	3300
CCF101097504000	975	4000

7 W/cm ² - 230 V monophasé		
CODE	L mm	Watt
CCF101013500650	135	650
CCF101015000850	150	850
CCF101017001000	170	1000
CCF101019001200	190	1200
CCF101021001350	210	1350
CCF101024501650	245	1650
CCF101028002000	280	2000
CCF101036002600	360	2600
CCF101043503300	435	3300
CCF101051004000	510	4000

7 W/cm ² - 230 V monophasé		
CODE	L mm	Watt
CCZ161020001000	200	1000
CCZ161024001250	240	1250
CCZ161027001500	270	1500
CCZ161031001750	310	1750
CCZ161035002000	350	2000
CCZ161042002500	420	2500
CCZ161049003000	490	3000
CCZ161056003500	560	3500
CCZ161063004000	630	4000
CCZ161092006000	920	6000

NOTE:
NO 2" ½ (code F = Z) EXECUTION
FORESEEN IN THIS FAMILY

NOTE:
NO 2" ½ (code F = Z) EXECUTION
FORESEEN IN THIS FAMILY

NOTE:
ONLY 2" ½ (code F = Z) EXECUTION
FORESEEN IN THIS FAMILY

ATTENTION

To define exactly the code of the desired heater:

- substitute letters “CC” with the Contact Head Code
(23 = IP40, 71 = IP65 without thermostat, 72 = IP65 with thermostat)
- substitute letter “F” (if present) with the plug-thread code
(T = 1" ¼ gas, U = 1" ½ gas, V = 2" gas, Z = 2" ½ gas)

N° 3 elements Ø 10, 3-bents, mounted on a 2" ½ plug

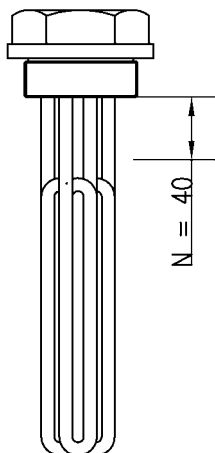

N° 3 elements Ø 10

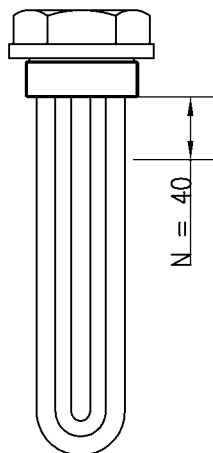

N° 3 elements Ø 16

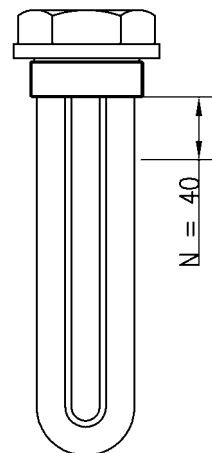

2 W/cm ² - 400 V tri-phase/star		
CODE	L mm	Watt
CCZ103019001000	190	1000
CCZ103021501200	215	1200
CCZ103026001500	260	1500
CCZ103032002000	320	2000
CCZ103039002500	390	2500
CCZ103045003000	450	3000
CCZ103052003500	520	3500
CCZ103072005000	720	5000

2 W/cm ² - 400 V tri-phase/star		
CODE	L mm	Watt
CCF103033001000	330	1000
CCF103038501200	385	1200
CCF103046001500	460	1500
CCF103059002000	590	2000
CCF103072002500	720	2500
CCF103086003000	860	3000
CCF103099003500	990	3500

2 W/cm ² - 400 V tri-phase/star		
CODE	L mm	Watt
CCZ163056003000	560	3000
CCZ163068003750	680	3750
CCZ163081004500	810	4500
CCZ163093005250	930	5250
CCZ163106006000	1060	6000

7 W/cm ² - 400 V tri-phase/star		
CODE	L mm	Watt
CCZ103013502000	135	2000
CCZ103015002500	150	2500
CCZ103017003000	170	3000
CCZ103019003500	190	3500
CCZ103021004000	210	4000
CCZ103024505000	245	5000
CCZ103028006000	280	6000
CCZ103036008000	360	8000
CCZ103043510000	435	10000
CCZ103051012000	510	12000

7 W/cm ² - 400 V tri-phase/star		
CODE	L mm	Watt
CCF103021002000	210	2000
CCF103025002500	250	2500
CCF103029003000	290	3000
CCF103033003500	330	3500
CCF103036004000	360	4000
CCF103044505000	445	5000
CCF103051006000	510	6000
CCF103067008000	670	8000
CCF103082010000	820	10000
CCF103097012000	970	12000

7 W/cm ² - 400 V tri-phase/star		
CODE	L mm	Watt
CCZ163035006000	350	6000
CCZ163044008000	440	8000
CCZ163054010000	540	10000
CCZ163063012000	630	12000
CCZ163077015000	770	15000
CCZ163092018000	920	18000
CCZ163101020000	1010	20000

NOTE:

ONLY 2" ½ (code F = Z) EXECUTION FORESEEN IN THIS FAMILY and IT IS NOT POSSIBLE TO REQUEST THE THERMOSTAT (CC code = 72)

NOTE:

NO 1" ¼ (code F = U) EXECUTION FORESEEN IN THIS FAMILY and NO THERMOSTAT (CC code = 72) CAN BE REQUESTED IF 1" ½ PLUG IS EMPLOYED

NOTE:

ONLY 2" ½ (code F = Z) EXECUTION FORESEEN IN THIS FAMILY

ATTENTION

To define exactly the code of the desired heater:

- substitute letters "CC" with the Contact Head Code (23 = IP40, 71 = IP65 without thermostat, 72 = IP65 with thermostat)
- substitute letter "F" (if present) with the plug-thread code (T = 1" ¼ gas, U = 1" ½ gas, V = 2" gas, Z = 2" ½ gas)

DATA REQUIRED FOR A CORRECT DEFINITION OF A HEATER MOUNTED ON THREADED PLUG

To design a plug-mounted heater a set of data is required. The availability of all the data is a pre-requisite for an optimum sizing and for a precise definition of the heating power. The Table 1 presented hereunder summarises the required data.

Table 1: data required to design a plug-mounted heater

Design Data	Notes	
Thermodynamic Data		
Fluid Note: More information on fluids characteristics are contained in the " Useful Technical Information " Volume	⇒ water ⇒ oil ⇒ other (please specify).....	
Fluid Quantity	⇒ in litres. If variable, please specify min. and max	
Tank Volume and dimensions	⇒ in m ³ (volume) and mm (dimensions)	
Thermal Insulation	⇒ Please specify if the tank is thermally insulated	
Design pressure	⇒ in bar absolute	
Maximum operating pressure	⇒ in bar absolute	
Design Temperature	⇒ in degrees centigrade	
Temperature at start up	⇒ in degrees centigrade	
Required Temperature	⇒ in degrees centigrade	
Plant start up time	⇒ Please specify the maximum time available for the heater to bring the fluid to the required temperature. (Attention! This datum shall be carefully evaluated to avoid an over sizing of the heater electric power)	
Installation	⇒ Horizontal / Vertical (in this case, please make sure that the liquid level is always above the neutral section threshold) ⇒ Outdoor / Indoor	
Type of connection to the plant	⇒ please specify the coupling thread	
Envelope	⇒ Please specify max. envelope, all included	
Electrical Data		
Installed Power	⇒ in kW	
Power Supply Voltage	⇒ in Volt	
Type of Electrical connection	⇒ Star / Delta / Monophase	
Contact Head Protection	⇒ IP 00/40/65	
Cable glands (if required)	Please specify: material and Φ external of the power supply cable	
Control		
Power	⇒ On/Off / SCR (Solid Control Relais) / On/Off + SCR	
Fluid thermal sensor	⇒ please specify number and type	
Sheath thermal sensor	⇒ please specify number and type	
Certifications and Calculations		
ATEX Certification	⇒ see Explosion Proof Heaters catalogue	

NOTE: Data in bold character must be provided to insure a correct sizing of the heater. For the remaining data, missing specific customer information, Masterwatt standards will be applied